

# Tabletop

## Bella Pizza Maker

Instructional Video



Promotional Video



**giles &  
posner®**

**INSTRUCTION MANUAL**

Please retain instructions for future reference.

## **Safety Instructions**

When using electrical appliances, basic safety precautions should always be followed.

Check that the voltage indicated on the rating plate corresponds with that of the local network before connecting the appliance to the mains power supply.

Children aged from 8 years and people with reduced physical, sensory or mental capabilities or lack of experience and knowledge can use this appliance, only if they have been given supervision or instruction concerning use of the appliance in a safe way and understand the hazards involved.

Children should be supervised to ensure that they do not play with the appliance.

Unless they are older than 8 and supervised, children should not perform cleaning or user maintenance.

This appliance is not a toy.

If the power supply cord, plug or any part of the appliance is malfunctioning or if it has been dropped or damaged, cease using the product immediately to avoid potential injury.

This appliance contains no user serviceable parts, only a qualified electrician should carry out repairs. Improper repairs may place the user at risk of harm.

Keep the appliance and its power supply cord out of reach of children.

Keep the appliance out of the reach of children when it is switched on or cooling down.

Keep the appliance and its power supply cord away from heat or sharp edges that could cause damage.

Keep the power supply cord away from any parts of the appliance that may become hot during use.

Keep the appliance away from other heat emitting appliances.

Do not allow the power supply cord to hang over worktops, touch hot surfaces or become twisted.

Do not immerse the electrical components of the appliance in water or any other liquid.

Do not operate the appliance with wet hands.

Do not leave the appliance unattended whilst connected to the mains power supply.

Do not remove the appliance from the mains power supply by pulling the cord; switch it off and remove the plug by hand.

Do not pull or carry the appliance by its power supply cord.

Do not use the appliance for anything other than its intended use.

Do not use any accessories other than those supplied.

Do not use this appliance outdoors.

Do not store the appliance in direct sunlight or in high humidity conditions.

Do not move the appliance whilst it is in use.

Do not touch any sections of the appliance that may become hot during use, as this may cause injury.

Do not use the appliance near or below flammable materials, such as curtains, wall cupboards or shelves.

Always unplug the appliance after use and before any cleaning or user maintenance.

Always unplug the appliance after use and ensure it has cooled fully before performing any cleaning, user maintenance or storing away.

Always use the appliance on a stable, heat-resistant surface, at a height that is comfortable for the user.

Always preheat the cooking plate before starting to cook.

Use of an extension cord with the appliance is not recommended.

This appliance should not be operated by means of an external timer or separate remote control system, other than that supplied with this appliance.

This appliance is intended for domestic use only. It should not be used for commercial purposes.

The door or the outer surface of the appliance may get hot during operation.



**CAUTION:** Hot surface – do not touch any sections or surfaces of the appliance that may become hot or the heating components of the appliance.

**WARNING:** Keep the appliance away from flammable materials.

## **Care and Maintenance**

**STEP 1:** Before attempting any cleaning or maintenance, unplug the pizza oven from the mains power supply and allow to fully cool.

**STEP 2:** Wipe the pizza oven housing with a soft, damp cloth and dry thoroughly.

**STEP 3:** The pizza stone may have the appearance of peeling paint. This is baked-on grease build-up which has turned to carbon and is flaking off. Remove residue using the pizza peels provided. If the carbon is difficult to remove, a mild, abrasive cloth can be used.

**STEP 4:** Clean the pizza stone with warm, soapy water using a non-abrasive cloth, then rinse with warm water.

Never use harsh or abrasive cleaning detergents or scourers to clean the pizza oven, as this could damage the surface.

**NOTE:** The pizza oven should be cleaned after each use.

Do not immerse the pizza stone in water or any other liquid.

## Description of Parts

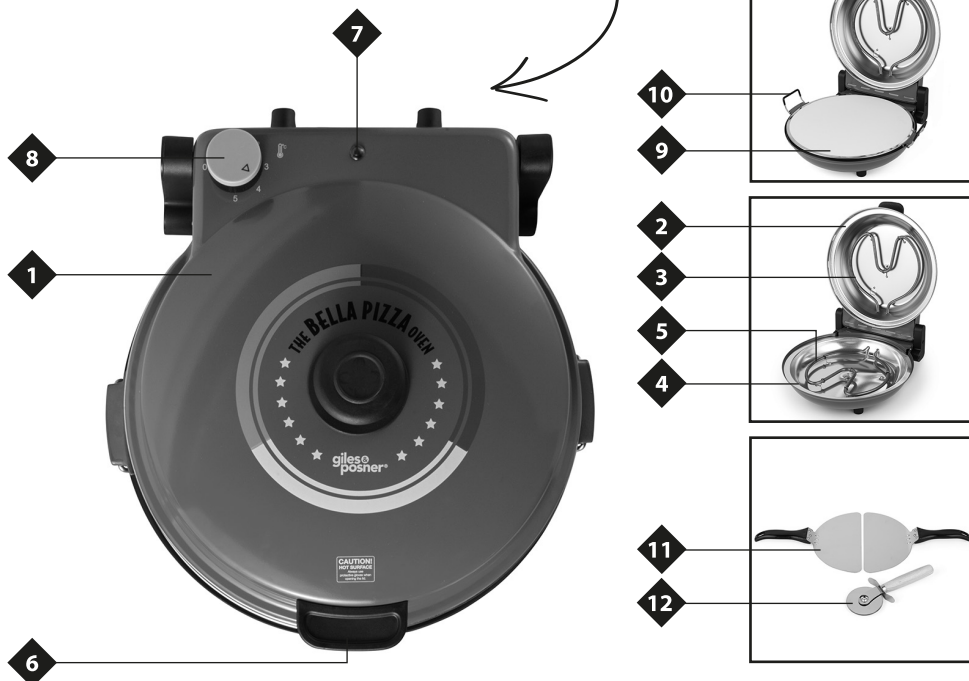

- |                          |                                |
|--------------------------|--------------------------------|
| 1. Pizza Oven main unit  | 7. Power/ready indicator light |
| 2. Top cover             | 8. Temperature control dial    |
| 3. Top heating element   | 9. Ceramic pizza stone         |
| 4. Lower cover           | 10. Pizza stone handles        |
| 5. Lower heating element | 11. Metal pizza peels (qty. 2) |
| 6. Cool touch handles    | 12. Pizza cutter               |

## Instructions for Use

### Before First Use

**STEP 1:** Check that the pizza oven is switched off and unplugged from the mains power supply.

**STEP 2:** Wipe the pizza oven exterior housing with a soft damp cloth and dry thoroughly.

**NOTE:** When using the pizza oven for the first time, a slight smoke or odour may be emitted. This is normal and will soon subside. Allow for sufficient ventilation around the pizza oven.

### Using the Pizza Oven

**STEP 1:** Place the pizza oven main unit onto a flat, stable, heat-resistant surface, at a height that is comfortable for the user.

**STEP 2:** Lift the top cover and place the ceramic pizza stone into the pizza oven; push down the handles to secure into place.

**STEP 3:** Plug in and switch on the pizza oven at the mains power supply. Make sure the temperature control dial is set to '0'.

**STEP 4:** Select heat setting 2. The indicator light will turn on, signalling that the pizza oven is heating up.

**STEP 5:** Preheat the pizza oven for approx. 10 minutes. The indicator light will turn off once the required temperature has been reached.

**STEP 6:** Prepare the ingredients that are to be cooked whilst the pizza oven is preheating.

**STEP 7:** Once preheated for 10 minutes, select the required heat setting by turning the temperature control dial in a clockwise direction.

**STEP 8:** Assemble the pizza, place onto the ceramic pizza stone and close the top cover.

**STEP 9:** Cook the pizza for the desired time, depending on preference of finish, the type of ingredients, the thickness of the pizza base and the temperature used. Ensure the pizza is turned round halfway through cooking.

**STEP 10:** Once cooking is complete, carefully remove the pizza with one of the metal pizza peels provided, being careful not to damage the ceramic pizza stone.

**STEP 11:** Turn the temperature control dial in an anticlockwise direction to '0', then switch off and unplug the pizza oven from the mains power supply. Allow the pizza oven to cool down before cleaning.

**CAUTION:** Exercise caution during cooking; the pizza oven will emit steam.

**WARNING:** The pizza oven and ceramic pizza stone get very hot during use; always use heat-resistant gloves to avoid injury.

### Temperature Table

Setting	Temperature
1	165 °C
2	210 °C
3	260 °C
4	340 °C
5	380 °C

<b>Type of Pizza</b>	<b>Approximate Cooking Time/Temperature</b>
Ready-made fresh pizza.	Cook on temperature setting '5' for approx. 4–5 minutes.
Pre-made frozen pizza.	Cook on temperature setting '2' for approx. 3–4 minutes to defrost, then heat up to temperature setting '5' for a further 5–6 minutes. Adjust time accordingly for thin crust and deep pan.
Pre-rolled fresh or homemade dough with fresh toppings.	Cook on temperature setting '5' for approx. 4–6 minutes. If meat is being used, adjust the cooking time to ensure the meat is cooked fully.

### **Storage**

Check that the pizza oven is cool, clean and dry before storing in a cool, dry place.  
Never wrap the cord tightly around the pizza oven; wrap it loosely to avoid causing damage.

### **Specifications**

Product code: EK5666

Input: 220–240 V ~ 50–60 Hz

Output: 1200 W

# Recipes

\*Any recipe images used in this instruction manual are intended for illustrative purposes only.





## Classic Pizza Dough

This dough is perfect for making fresh pizza from scratch. The longer the dough proves the better, but this dough needs a minimum of approx. 6–8 hours.

### Ingredients

500 g strong white flour	15 g fine sea salt
350 g water	0.4 g dried yeast

### Method

Warm the water to approx. 30–35 °C and dissolve the fine sea salt into it. Add the yeast, rest for 1 minute and then stir until dissolved

Add this mixture to the flour and mix together by hand. Using a pincer-like grip, squeeze the chunks of dough with the thumbs and fingertips to reduce the size of the chunks

Once combined, cut the dough over itself 2–3 times by stretching and folding it. Allow the dough to rest for approx. 20 minutes.

Knead the dough on a floured surface. Place the dough into a lightly oiled bowl and cover with an airtight lid. Leave to prove for approx. 2 hours at room temperature.

On a floured surface, divide the mixture and shape it into equal-sized balls. Place on a floured baking sheet, re-cover with a damp tea towel and allow to prove for approx. 6 hours.

## Passata Pizza Sauce

### Ingredients

8 large tomatoes, chopped	1 small red onion, diced	2 tbsp tomato purée
2 garlic cloves, peeled and chopped	Small handful of fresh basil leaves	1 tbsp olive oil
		Black pepper, to taste

### Method

In a pan, gently fry the red onion in the olive oil until soft.

Add the tomatoes, garlic, basil and black pepper to the pan and stir. Bring to the boil.

Mix in the tomato purée and simmer for approx. 10–15 minutes until fully reduced; the passata should be thick enough to be spread on the pizza base. If not, continue simmering until it thickens.

**Meat Pizzas****New Yorker****Ingredients**

245 g passata	55 g ricotta	Oil from the roasted garlic cloves
140 g mozzarella, thinly sliced	30 g pepperoni, sliced	Parmesan, grated, to taste
115 g Sicilian-style sausage, thinly sliced	5 garlic cloves, roasted	Dried oregano, to garnish

**Method**

Roll the pizza dough to the desired thickness and size.

Spoon the passata into the middle of the pizza and spread using the back of the spoon.

Arrange the mozzarella on top, starting from the outside and working into the centre, leaving a 2 ½ inch border. Arrange the pepperoni, sausage and ricotta cheese evenly. Scatter the garlic cloves and then drizzle the garlic oil over the top.

Slide the pizza onto the ceramic pizza stone and cook for at least 5 minutes on heat setting '5'.

Cook further according to preference.

**Ham, Mushroom and Ricotta****Ingredients****For the Crema di Ricotta**

4 tbsp ricotta	2 tsp milk	Salt and pepper, to taste
----------------	------------	---------------------------

**For the Mushrooms**

40 g wild mushrooms	1 tbsp butter	Salt, to taste
1 tbsp olive oil		

**Toppings**

60 g mozzarella, torn into small chunks	50 g cooked ham, sliced	4 fresh basil leaves
	4 tbsp passata	

**Method**

To make the crema di ricotta, combine the milk and ricotta together in a bowl, until smooth.

Season to taste with salt and pepper.

To make the mushrooms, toss the mushrooms in the olive oil and season to taste with salt and pepper. Transfer to a pan and fry in the butter until cooked.

Roll the pizza dough to the desired thickness and size.

Spoon the passata into the middle of the pizza and spread using the back of the spoon.

With a spoon, add dollops of the crema di ricotta to the pizza base. Scatter the mushrooms, mozzarella, basil and ham and drizzle the pizza with olive oil.

Slide the pizza onto the ceramic pizza stone and cook for at least 5 minutes on heat setting '5'.

Cook further according to preference.



## Hawaiian

### Ingredients

90 g passata	15 g pecorino, grated	1 tbsp extra-virgin olive oil
50 g cooked ham, sliced	¼–½ onion, diced	Chili flakes
40 g mozzarella, grated	1 pineapple	Fine sea salt, to taste

### Method

Peel the pineapple using a sharp knife and remove the core. Cut the pineapple into small chunks. Combine the pineapple and onion with the olive oil and season to taste with the sea salt and chili flakes.

Roll the pizza dough to the desired thickness and size.

Place the pineapple and onion mixture into a cast iron pot and roast in the oven at 210 °C for approx. 10 minutes to caramelize the pineapple.

Spoon the passata into the middle of the pizza and spread using the back of the spoon.

Sprinkle the pecorino cheese onto the pizza base and add the ham and roasted pineapple and onion on top. Top with the grated mozzarella.

Slide the pizza onto the ceramic pizza stone and cook for at least 5 minutes on heat setting '5'. Cook further according to preference.

## Vegetarian Pizza

### Ingredients

256 g passata	1 chili, finely sliced	4 tsp salted capers
80 g mozzarella, torn	½ garlic clove, finely chopped	½ tsp dried oregano
6–8 olives	2 tbsp olive oil	Black pepper, to taste
3 basil leaves, torn		

### Method

Soak the salted capers in water for at least 1 hour, then drain.

In a saucepan, cook the garlic, chili, capers and olives in 1 tbsp of olive oil, until the garlic starts to brown.

Roll the pizza dough to the desired thickness and size.

Spoon the passata into the middle of the pizza and spread using the back of the spoon.

Add the mozzarella, a sprinkle of oregano and a drizzle of olive oil.

Slide the pizza onto the ceramic pizza stone and cook for at least 5 minutes on heat setting '5'.

Cook further according to preference.

Once cooked as desired, add the pan-fried mixture to the pizza and top with the basil and black pepper, to taste.

## Dessert Pizza

### Ingredients

230 g cream cheese	4 tbsp sugar
60 g chocolate chips	1 tsp vanilla extract

### For the streusel topping:

75 g granulated sugar	2 tbsp butter, melted	¼ tsp vanilla extract
47 g plain flour	2 tbsp brown sugar	

### Method

Roll the pizza dough to the desired thickness and size.

Sprinkle 120 g of the mini chocolate chips evenly over the pizza dough.

Heat the cream cheese until it is just melted. Add the sugar and vanilla extract and stir well.

Pour the cream cheese mixture onto the pizza dough and spread using the back of a spoon. Top with the remaining chocolate chips.

For the streusel, combine the flour, sugar and brown sugar in a bowl. Combine the butter and vanilla extract in a separate bowl and pour into the flour mixture. Mix until combined; there should be small lumps in the streusel topping. Sprinkle the streusel topping over the pizza.

Slide the pizza onto the ceramic pizza stone and cook for at least 5 minutes on heat setting '5'. Cook further according to preference.

## UK PLUGS ONLY

### Connection to the mains

Please check that the voltage indicated on the product corresponds with your supply voltage.

### Important

As the colours in the mains lead of this appliance may not correspond with the coloured markings identifying the terminals in your plug, please proceed as follows:

The wires in the mains lead are coloured in accordance with the following code:

Blue Neutral (N)

Brown Live (L)

Green/Yellow Earth ( $\perp$ )

FOR UK USE ONLY - Plug fitting details  
(where applicable).

The wire coloured BLUE is the NEUTRAL and must be connected to the terminal marked N or coloured BLACK.

The wire coloured BROWN is the LIVE wire and must be connected to the terminal marked L or coloured RED.

The wire coloured GREEN/YELLOW must be connected to the terminal marked with the letter E or marked  $\perp$ .

On no account must either the BROWN or the BLUE wire be connected to the EARTH terminal ( $\perp$ ).

Always ensure that the cord grip is fastened correctly.

The plug must be fitted with a fuse of the same rating already fitted and conforming to BS 1362 and be ASTA approved.

If in doubt consult a qualified electrician who will be pleased to do this for you.

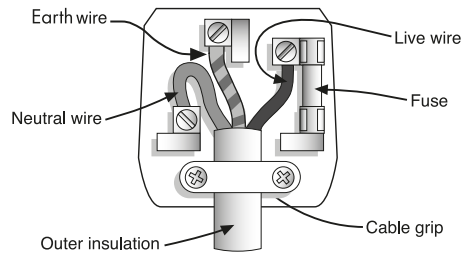

### Non-rewireable mains plug

If your appliance is supplied with a non-rewireable plug fitted to the mains lead and should the fuse need replacing, you must use an ASTA approved one (conforming to BS 1362 of the same rating).

If in doubt, consult a qualified electrician who will be pleased to do this for you.

If you need to remove the plug - DISCONNECT IT FROM THE MAINS and then cut it off the mains lead and immediately dispose of it safely. Never attempt to reuse the plug or insert it into a socket outlet as there is a danger of an electric shock.

**UP Global Sourcing UK Ltd.,  
Victoria Street, Manchester OL9 0DD. UK.  
Edmund-Rumpler Straße 5, 51149 Köln. Germany.**

If this product does not reach you in an acceptable condition please contact our Customer Services Department at [www.upgs.com/giles-posner/](http://www.upgs.com/giles-posner/).

Please have your delivery note to hand as details from it will be required.

If you wish to return this product please return it to the retailer from where it was purchased with your receipt (subject to their terms and conditions).

### **Guarantee**

All products purchased as new carry a manufacturer's guarantee; the time period of the guarantee will vary dependent upon the product. Where reasonable proof of purchase can be provided, Giles and Posner will provide a standard 12 month guarantee with the retailer from the date of purchase. This is only applicable when products have been used as instructed for their intended, domestic use. Any misuse or dismantling of products will invalidate any guarantee.

Under the guarantee, we undertake to repair or replace free of any charge any parts found to be defective. In the event that we cannot provide an exact replacement, a similar product will be offered or the cost refunded. Any damages from daily wear and tear are not covered by this guarantee, nor are consumables such as plugs, fuses etc.

Please note that the above terms and conditions may be updated from time to time and we therefore recommend that you check these each time you revisit the website.

Nothing in this guarantee or in the instructions relating to this product excludes, restricts or otherwise affects your statutory rights.

### **Disposal of Waste Batteries and Electrical and Electronic Equipment**



This symbol on the product, its batteries or its packaging means that this product and any batteries it contains must not be disposed of with household waste. Instead, it is the user's responsibility to hand this over to an applicable collection point for the recycling of batteries and electrical and electronic equipment. This separate collection and recycling will help to conserve natural resources and prevent potential negative consequences for human health and the environment due to the possible presence of hazardous substances in batteries and electrical and electronic equipment, which could be caused by inappropriate disposal. Some retailers provide take-back services which allow the user to return exhausted equipment for appropriate disposal. **It is the user's responsibility to delete any data on electrical and electronic equipment prior to disposal.** For more information about where to drop batteries, electrical and electronic waste off, please contact the local city/municipality office, household waste disposal service, or the retailer.

Find us on 

[www.facebook.com/GilesAndPosner](http://www.facebook.com/GilesAndPosner)

To be eligible for the extended guarantee,  
go to **[guarantee.upgs.com/giles-and-posner](http://guarantee.upgs.com/giles-and-posner)** and  
register your product within 30 days of purchase.

Manufactured by:  
UP Global Sourcing UK Ltd.,  
Victoria Street, Manchester OL9 0DD. **UK.**  
Edmund-Rumpler Straße 5, 51149 Köln. **Germany.**

**MADE IN CHINA.**

**[www.upgs.com/giles-posner](http://www.upgs.com/giles-posner)**

©Giles & Posner trademark. All rights reserved.



CD110423/MD260423/V2